

1

Setting up your Kenwood Audio/Video System

Spectrum 1050 AV

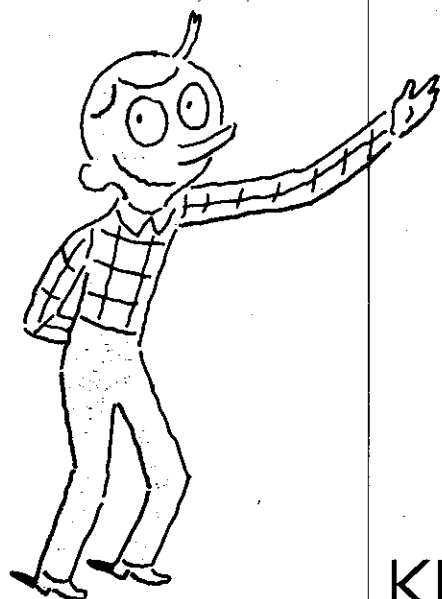

KENWOOD

Licensing

Manufactured under license from Dolby Laboratories Licensing Corporation. Additionally licensed under one or more of the following patents: US numbers 3,632,886; 3,746,792; and 3,959,590; Canadian numbers 1,004,603 and 1,037,877. 'Dolby', 'Pro Logic' and the  symbol are trademarks of Dolby Laboratories Licensing Corporation.

Safety first

WARNING:
**TO PREVENT FIRE OR ELECTRIC SHOCK, DO NOT
EXPOSE THIS UNIT TO RAIN OR MOISTURE.**

Safety Symbols

We've placed these safety symbols on the back of the unit.



CAUTION:

To prevent electric shock, match the wide blade of the plug to the wide slot in a wall socket, and insert fully.



The lightning bolt symbol is to alert you to the danger of electric shock from the operating of electric parts inside the unit.



The exclamation point symbol is to let you know that there are important operating and servicing instructions in this manual that you should read before you operate this unit.

Canadian IC Compliance Notice

This device complies with RSS-210 of Industry Canada. Operation is subject to the following two conditions: (1) this device may not cause interference, and (2) this device must accept any interference, including interference that may cause undesired operation of the device.

Rechargeable Battery Warning

If this unit uses a rechargeable battery, use the battery charger that came with the unit only. Do NOT take apart, damage, burn, or short circuit the battery, or expose it to heat—this could cause it to burst or to release toxic materials. Keep the battery away from children.

About the power supply

This unit is designed for operation in the USA and Canada using a power supply of AC 120 volts only.

Safety Precautions

Read this page carefully to ensure safe operation.

Please read all of the safety and operating instructions before operating this unit. Adhere to all warnings on the unit and in this manual. Follow all the safety and operating instructions. These safety and operating instructions should be retained for future reference.

- 1 Power sources.** The unit should be connected to a power supply only of the type described in this manual or as marked on the unit. If you are not sure of the type of power supply to your home, consult your unit dealer or local power company. For units intended to operate from battery power, or other sources, refer to the instruction manual.
- 2 Power-cord protection.** Power supply cords should be routed so that they are not likely to be walked on or pinched by items placed upon or against them, paying particular attention to cords at plugs, convenience receptacles, and the point where they exit from the unit.
- 3 CAUTION—Polarization.** This unit may be equipped with a polarized alternating-current line plug (a plug having one blade wider than the other). This plug will fit into the power outlet only one way. This is a safety feature. If you are unable to insert the plug fully into the outlet, try reversing the plug. If the plug should still fail to fit, contact your electrician to replace your outlet. Do not defeat the safety purpose of the polarized plug.
- 4 Ventilation.** Slots and openings in the cabinet are provided for ventilation and to ensure reliable operation of the unit and to protect it from overheating, and these openings must not be blocked or covered. The unit should be situated so that its location or position does not interfere with its proper ventilation.

To maintain good ventilation, do not put records or a table-cloth on the unit. Place the unit at least 4 inches away from the walls.

Do not use the unit on a bed, sofa, rug or similar surface that may block the ventilation openings. This unit should not be placed in a built-in installation such as a bookcase or rack unless proper ventilation is provided or the manufacturer's instructions have been adhered to.

5 Water and moisture. The unit should not be used near water, for example, near a bathtub, washbowl, kitchen sink, laundry tub, in a wet basement, or near a swimming pool, etc.

6 Temperature. The unit may not function properly if used at extremely low, or freezing temperatures. The ideal ambient temperature is above +41°F.

7 Heat. The unit should be situated away from heat sources such as radiators, heat registers, stoves, or other units (including amplifiers) that produce heat.

8 Electric Shock. Care should be taken so that objects do not fall and liquid is not spilled into the enclosure through openings. If a metal object, such as a hair pin or a needle, comes into contact with the inside of this unit, a dangerous electric shock may result. For families with children, never permit children to put anything, especially metal, inside this unit.

9 Enclosure removal. Never remove the enclosure. If the internal parts are touched accidentally, a serious electric shock might occur.

10 Cleaning. Unplug this unit from the wall outlet before cleaning. Do not use volatile solvents such as alcohol, paint thinner, gasoline, or benzene, etc. to clean the cabinet. Use a clean dry cloth.

11 Lightning. For added protection for this unit during a lightning storm, or when it is left unattended and unused for long periods of time, unplug it from the wall outlet and disconnect the antenna or cable system. This will prevent damage to the unit due to lightning and power-line surges.

12 Abnormal smell. If an abnormal smell or smoke is detected, immediately turn the power OFF and unplug the unit from the wall outlet. Contact your dealer or nearest service center.

13 Damage requiring service. The unit should be serviced by qualified service personnel when:

The power-supply cord or the plug has been damaged

Objects have fallen, or liquid has been spilled into the unit.

The unit has been exposed to rain or water.

The unit has been dropped, or the enclosure damaged.

The unit exhibits a marked change in performance.

The unit does not appear to operate normally by following the instruction manual. Adjust only those controls that are covered by the instruction manual as an improper adjustment of other controls may result in damage and will often require extensive work by a qualified technician to restore the unit to its normal operation.

14 Servicing. The user should not attempt to service the unit beyond that described in the instruction manual. All other servicing should be referred to qualified service personnel.

15 Power lines. An outside antenna system should not be located in the vicinity of overhead power lines or other electric light or power circuits, or where it can fall into such power lines or circuits. When installing an outside antenna system, extreme care should be taken to keep from touching such power lines or circuits as contact with them might be fatal.

16 AC outlets. Do not connect other audio equipment with a power consumption larger than that specified to the AC outlet on the rear panel. Never connect other electrical units, such as an iron or toaster, to it to prevent fire or electric shock.

17 Overloading. Do not overload wall outlets, extension cords, or integral convenience receptacles as this can result in a risk of fire or electric shock.

18 Attachment. Do not use attachments not recommended by the unit manufacturer as they may cause hazards.

19 Replacement parts. When replacement parts are required, be sure the service technician has used replacement parts specified by the manufacturer or have the same characteristics as the original parts. Unauthorized substitutions may result in fire, electric shock, or other hazards.

20 Safety check. Upon completion of any service or repairs to this unit, ask the service technician to perform safety checks to determine that the unit is in proper operating condition.

21 Carts and stands. Don't put this unit on a cart or stand that is unsteady or that can not support the unit's weight. If you move this unit on a cart or stand, be careful—quick stops, excessive force and pushing over or uneven surfaces, may cause the cart to overturn and damage your equipment.



FCC Warning

This equipment may generate or use radio frequency energy. Changes or modifications to this equipment may cause harmful interference unless the modifications are expressly approved in the instruction manual. The user could lose the authority to operate this equipment if an unauthorized change or modification is made.

Important

This equipment has been tested and found to comply with the limits for a Class B digital device, pursuant to Part 15 of the FCC Rules. These limits are designed to provide reasonable protection against harmful interference in a residential installation. This equipment may cause harmful interference to radio communications if it is not installed and used in accordance with the instructions. However, there is no guarantee that interference will not occur in a particular installation. If this equipment does cause harmful interference to radio or television reception, which can be determined by turning the equipment OFF and ON, the user is encouraged to try to correct the interference by one or more of the following measures:

- Reorient or relocate the receiving antenna
- Increase the separation between the equipment and integrated amplifier
- Connect the equipment into an outlet on a circuit different from that to which the integrated amplifier is connected
- Consult the dealer or an experienced radio/TV technician for help

Cable System Installer Notice

Article 820-40 of the NEC provides guidelines for proper grounding and, in particular, specifies that the cable ground shall be connected to the grounding system of the building, as close to the point of cable entry as practical.

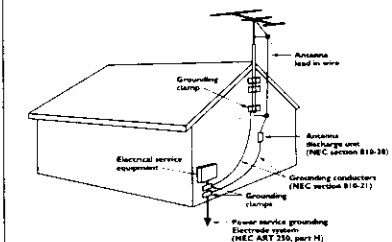

Contents

Safety First	3	Using an AM outdoor antenna (optional)	20
Welcome	6	Using a FM outdoor antenna (optional)	20
Unpacking	6	Connecting your video components	21
Did you get everything?	6	Connecting the system control cables	22
You may need to purchase	6	Connecting other audio components	23
You'll need these tools	6	Plugging in the power cords	24
Assembling the rack	7	Turning on the power	25
How to get replacement parts for your rack	11	Tuning the speakers	26
Placing your system	12	Setting the center speaker mode	26
Stacking your components in the rack	12	Calibrating the speaker levels	26
Assembling the speaker stands	12	Loading batteries into the remote	26
Placing the speakers on the stands	13	Doing the calibrating	26
Attaching feet to the subwoofer	13	Setting the subwoofer level	28
Positioning your speakers	13	Adjusting the delay time	29
Left and right speakers	13	Before you start	29
Center channel speaker	13	Doing the adjusting	29
Surround speakers	13	Warranty	31
Subwoofer	13		
Connecting your components	15		
Connecting your speakers	15		
Left and right speakers	15		
Surround speakers	15		
Center channel speaker	16		
Subwoofer	16		
Connecting your power amplifier	17		
Connecting your tuner, CD player, cassette deck, and optional turntable	18		
Connecting your antennas	19		
Connecting the antenna wires to the antenna jacks	19		
Using the AM indoor loop antenna (supplied)	19		
Using the FM indoor antenna (supplied)	19		

Welcome

Setting up your system isn't difficult, but getting your system up and running will be even easier if you follow the step-by-step directions in this manual.

Unpacking

Unpack all of the components carefully, and examine them for shipping damage. If any are damaged or fail to operate, notify your dealer immediately. If your system was shipped to you directly, notify the shipping company without delay. Only the person or company who originally received the system can file a claim against the carrier for shipping damage. Keep the original carton and packing materials in case you need to transport or ship your system.

Did you get everything?

Check the lists below to make sure you have everything. And before you start setting up the system, look at the list of tools and other items you need. If you're setting up other components along with your system, read the manual that came with each of those components to see what you need.

Amplifier parts

- Integrated amplifier (KA-996)
- Remote Control (RC-R0802)
- 2 Batteries for remote

Power amplifier parts

- Power amplifier (KM-996)
- Audio cable

Tuner parts

- Tuner (KT-596)
- FM indoor antenna
- AM loop antenna
- Loop antenna stand
- Audio cable
- System control cable

CD player parts

- CD Player (DP-R896)
- Audio cable
- System control cable

Cassette deck parts

- Cassette Deck (KX-W896)
- 2 Audio cables
- System control cable

Left and right front speaker parts

- 2 Front speakers (JL-1106)
- 2 Speaker wires

Speaker stand parts

- 2 speaker stand tops
- 2 Speaker stand supports
- 2 Speaker stand bases
- 1 Hardware bag

Subwoofer parts

- Subwoofer (SW-50)
- 4 feet
- 4 screws
- Speaker wire

Center and Surround speaker parts

- Center speaker (CRS-156 Center)

- 2 Surround speakers (CRS-156 Surround)
- 3 Speaker wires

Rack parts

- Left panel
- Right panel
- Rack base
- Rack top
- Rack bottom
- Top back panel
- Bottom back panel
- Fixed shelf
- Center shelf
- Removable shelf
- Glass door
- Hardware bag (see page 7 for contents of the hardware bag)

You may need to purchase

- Audio cables
- Video cables
- Speaker wire

You'll need these tools

- Screwdriver (slot and/or Phillips)
- Pliers

Assembling the rack

Hardware list

Before assembling your rack check to be sure that you received all of the hardware listed below.

Item	Description	Quantity
K	Top door hinge	1
L	Bottom door hinge	1
M	Magnetic latch	1
N	Catch plate	1
O	Catch plate pad	1
Q	Allen wrench	1
R	Cam lock pins	12
S	Cam lock pins	12
T	Shims	4
U	Washers	2
V	Wrench	2
W	Phillips head screws	16
X	Phillips head screws	4
Y	Door hinge nuts	2

Step 1

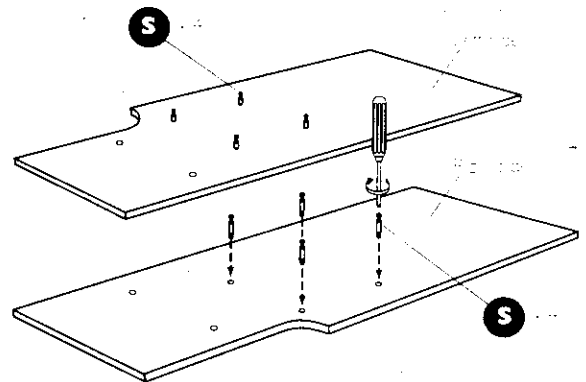

Step 2

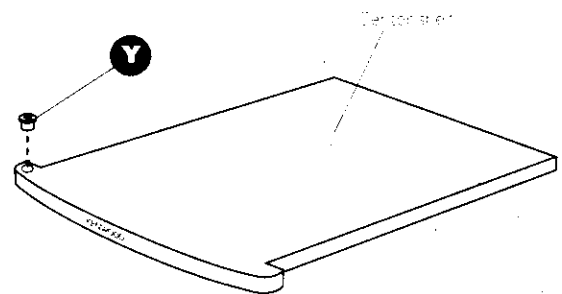

Step 3

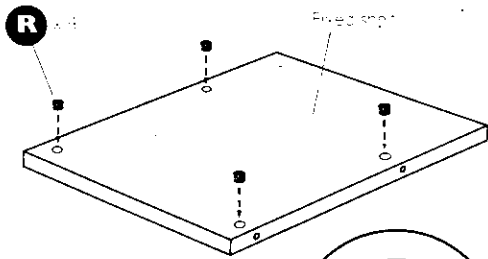
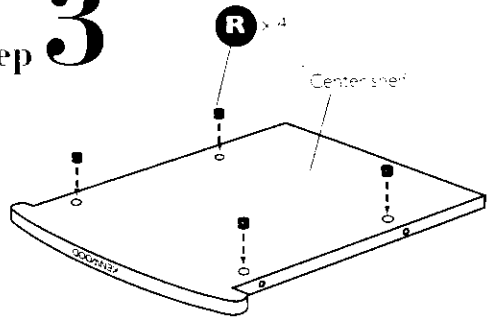

Arrow on top of cam points towards hole in edge

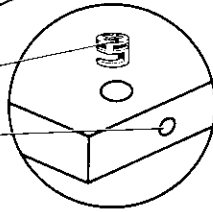

Step 4

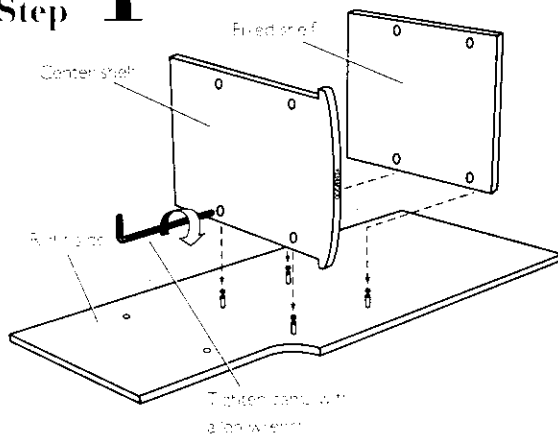

Step 5

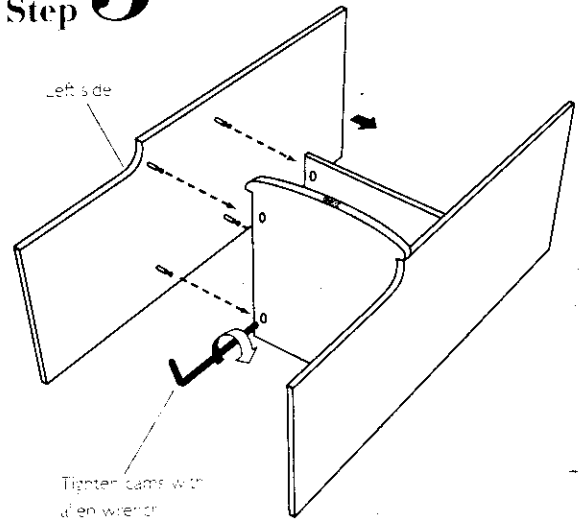

Step 6

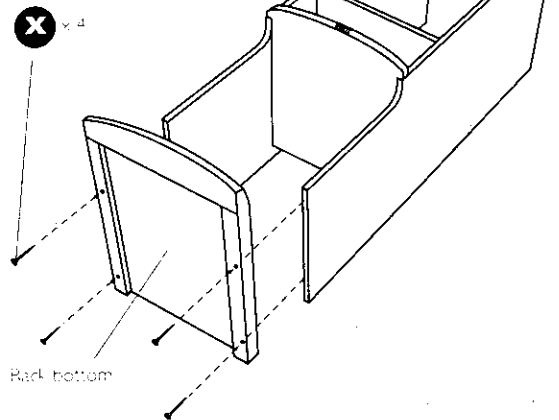

Step 7

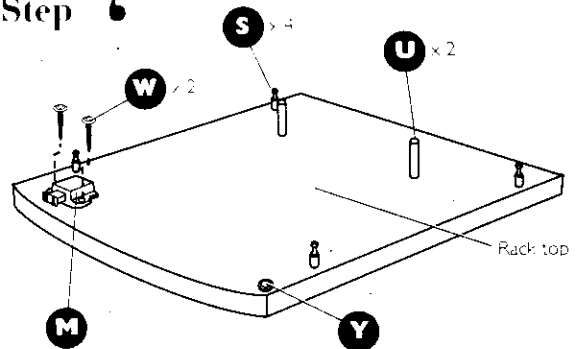

Step 8

Arrow on top of cam points towards hole in edge

R x 4

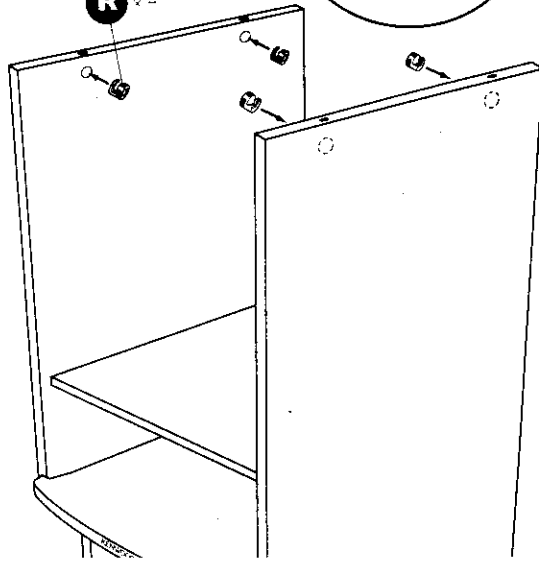

Step 9

Rack top

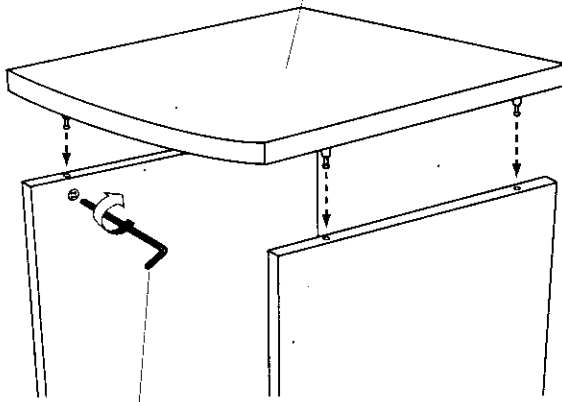

Tighten cam with Allen wrench

Step 10

Top back pane

W x 4

Bottom back pane

W x 10

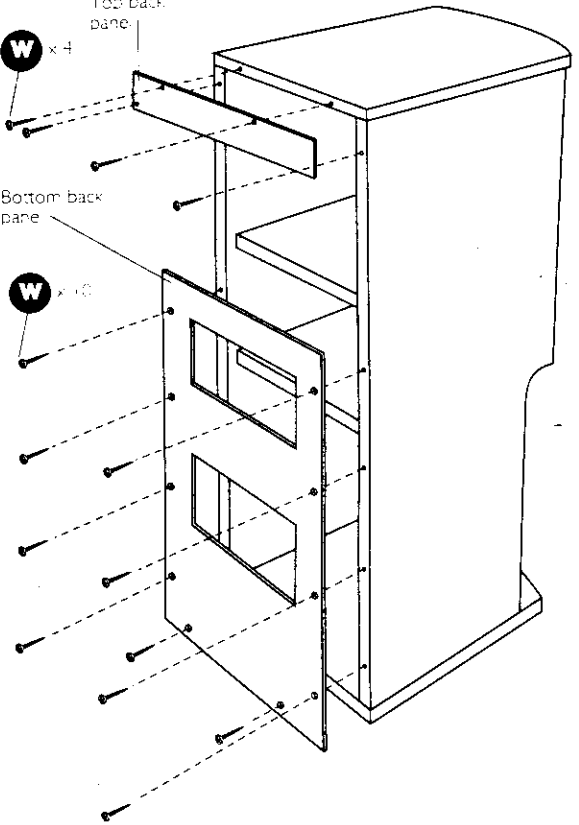

Step 11

Peel paper off of back

V

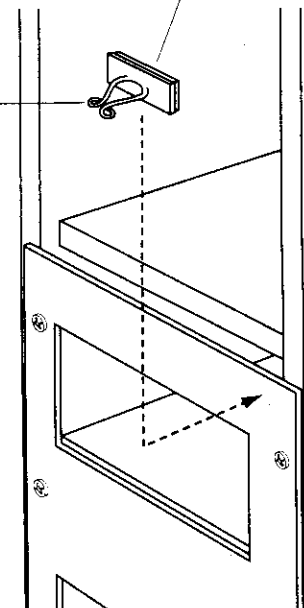

Step 12

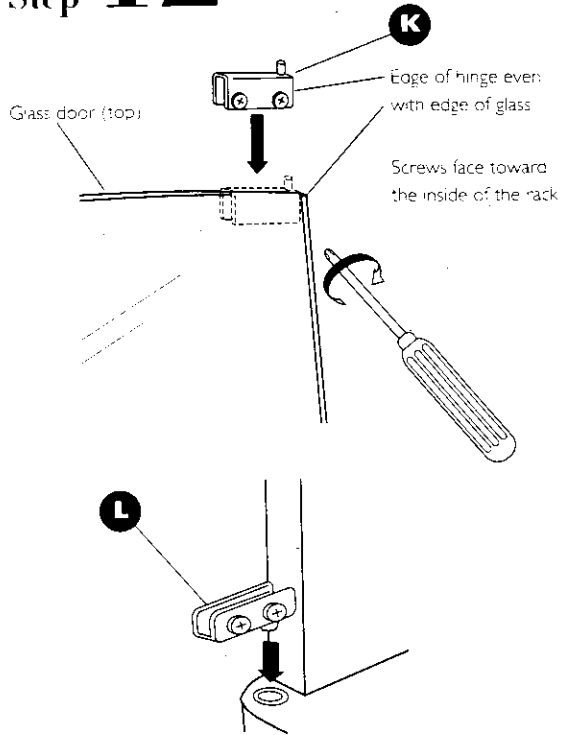

Step 13

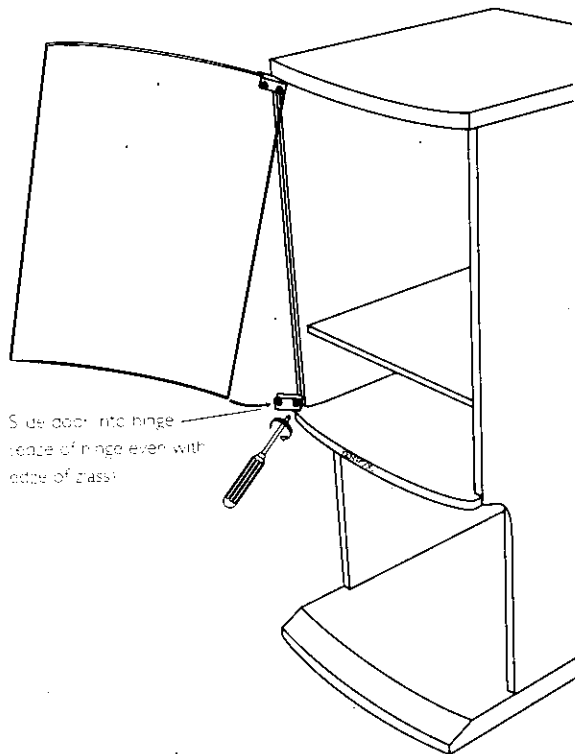

Step 14

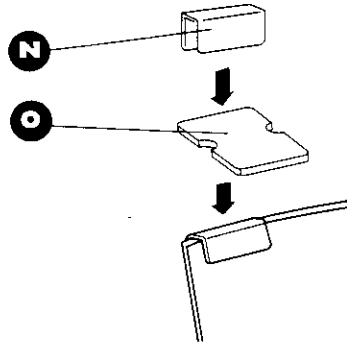

First close the door to see where the magnetic catch contacts it.

Attach the cushion **O** to the door where the magnetic catch contacted it.

Slip the catch plate **N** over the cushion.

How to get replacement parts for your rack

If any of the rack parts are missing or damaged, contact the following company for replacement parts:

Tocabi America
755 Otay Valley Road
Chula Vista, CA 91911
(619) 661-6136

Use the following parts list to identify missing or damaged parts:

Description	Quantity	Part Number
Rack top	1	XW1098
Right side panel	1	XW1104
Left side panel	1	XW1105
Fixed shelf	1	XW1099
Center shelf	1	XW1100
Removable shelf	1	XW1101
Rack bottom	1	XW1102
Bottom back panel	1	XW1103
Top back panel	1	XW0905
Glass door	1	G0265
Top door hinge	1	M0026
Bottom door hinge	1	M0027
Magnetic door catch	1	P0098
Catch plate	1	M0011
Catch plate pad	1	G0047
Allen wrench	1	M0018
Camlock cams	12	B0056
Camlock pegs	12	B0004
Shelf pegs	4	M0019
Wood dowels	2	W0981
Wire clips	2	P0117
Small screws	16	S0034
Long screws	4	S0025
Door hinge inserts	2	P0054

Placing your system

Stacking your components in the rack

To make sure that they're properly ventilated and stable, stack them according to the following diagram. If you're using a turntable, place it on top of the rack.

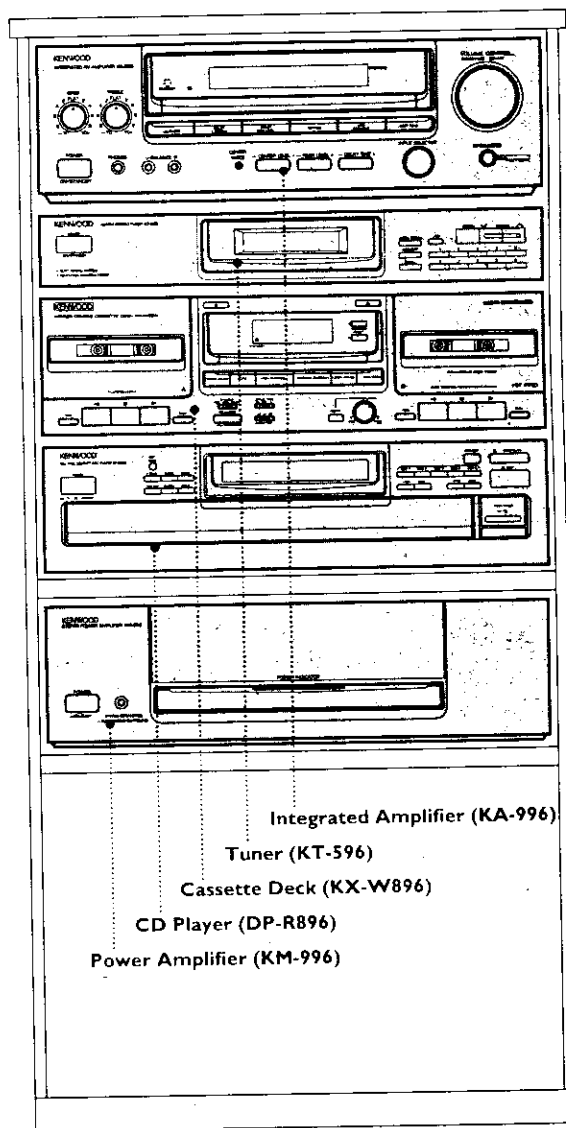

Assembling the speaker stands

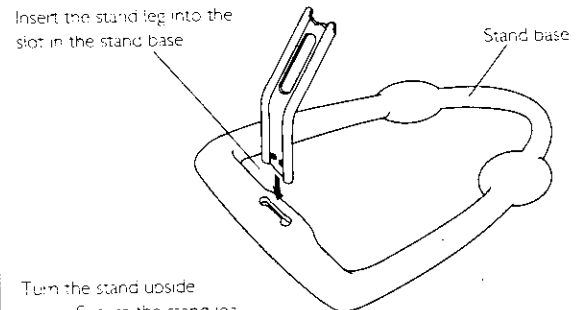
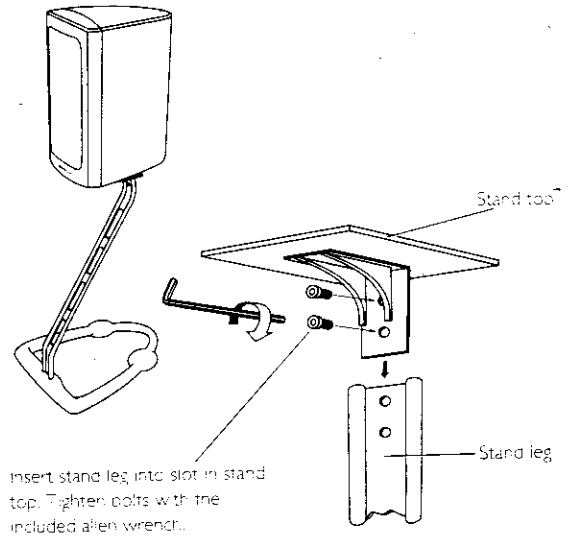

Turn the stand upside down. Secure the stand leg to the base using the supplied nuts, bolts and washers. Tighten the bolts with the included Allen wrench.

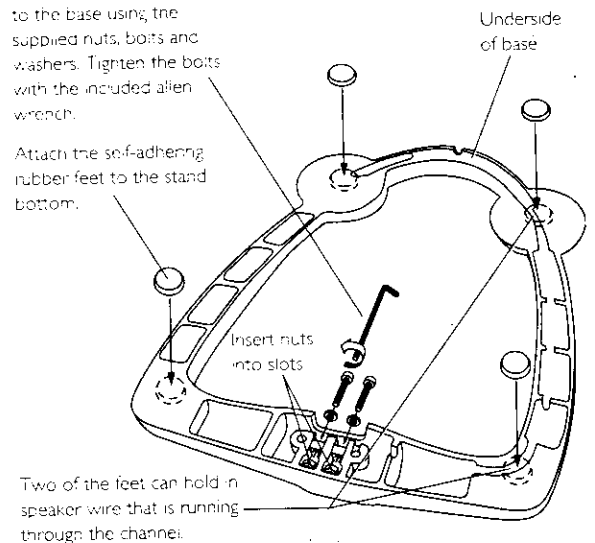

Placing the speakers on the stands

- 1 Hold the speaker behind the top of the stand.
- 2 Line up the grooves in the speaker mounts with the edges of the stand top.
- 3 Push the speaker onto the stand so that the stand top is inserted all the way into the speaker mount grooves.

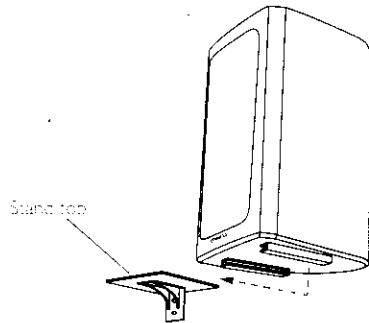

Tip:

You can hide the speaker wires by running them through the channels in the speaker stand supports and bases.

Attaching feet to the subwoofer

If you want, you can use the 4 included feet to elevate the subwoofer above thick carpeting, etc. (The subwoofer will fit inside the rack with the feet attached).

- 1 Turn the subwoofer upside-down.
- 2 Position one of the feet over the pre-drilled hole at one of the corners.
- 3 Using the included screw, attach the foot to the subwoofer.
- 4 Repeat steps 2 and 3 for the other 3 feet.

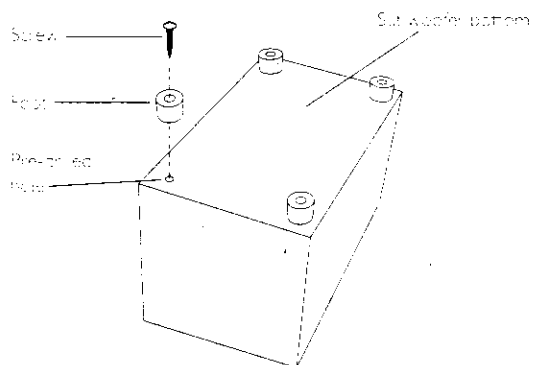

Positioning your speakers

The speaker locations on page 14 are excellent for many different rooms, and you can vary them to fit your particular room. Experiment with speaker locations to get the most out of your system.

The left, right, and center speakers are magnetically shielded so you can place them next to your TV without worrying about picture discoloration.

A few tips for placing your speakers:

Left and right speakers

- For the best stereo effect, place the speakers at least 2 feet from the sides of the TV. However, keep them close enough to the screen that the sound from the speakers seems to be coming from the screen.
- To enhance the stereo effect (especially if the speakers are more than 8 feet apart), rotate each speaker slightly toward the listening area.

Center channel speaker

- Make sure that the speaker is aimed directly toward the listeners at seated ear level. If you do place it above or below ear level, aim it toward the listeners by tilting it up or down.
- Make sure the center speaker is about the same height as the left and right speakers. Never place it more than 2 feet higher or lower than the left and right speakers.

Surround speakers

- Mount each speaker at least 2 feet above the listeners' heads, with the back of the cabinet (the side with the speaker jack) flush against the wall. You can hang the speakers on the wall using ordinary picture hangers, or you can place them on shelves.

Subwoofer

- You can place the subwoofer inside the bottom portion of the component rack, if you want, or you can place it elsewhere in the room. If you place the subwoofer near your TV, it may distort the picture color. If this happens, move the subwoofer away from the TV until the picture returns to normal.

- A subwoofer doesn't send sound waves in a particular direction, so you can place it almost anywhere in the room
- For the smoothest match between the subwoofer and the front speakers, place them all in a straight line.
- For deeper bass, place the subwoofer next to a wall. For the deepest bass, place the subwoofer in a corner. However, this may yield uneven bass throughout the room. Some areas may have too much bass, while other areas may not have enough.
- Once you settle on a location, be sure to leave yourself some room for minor movements of a few inches to help fine-tune the sound in the seating area.

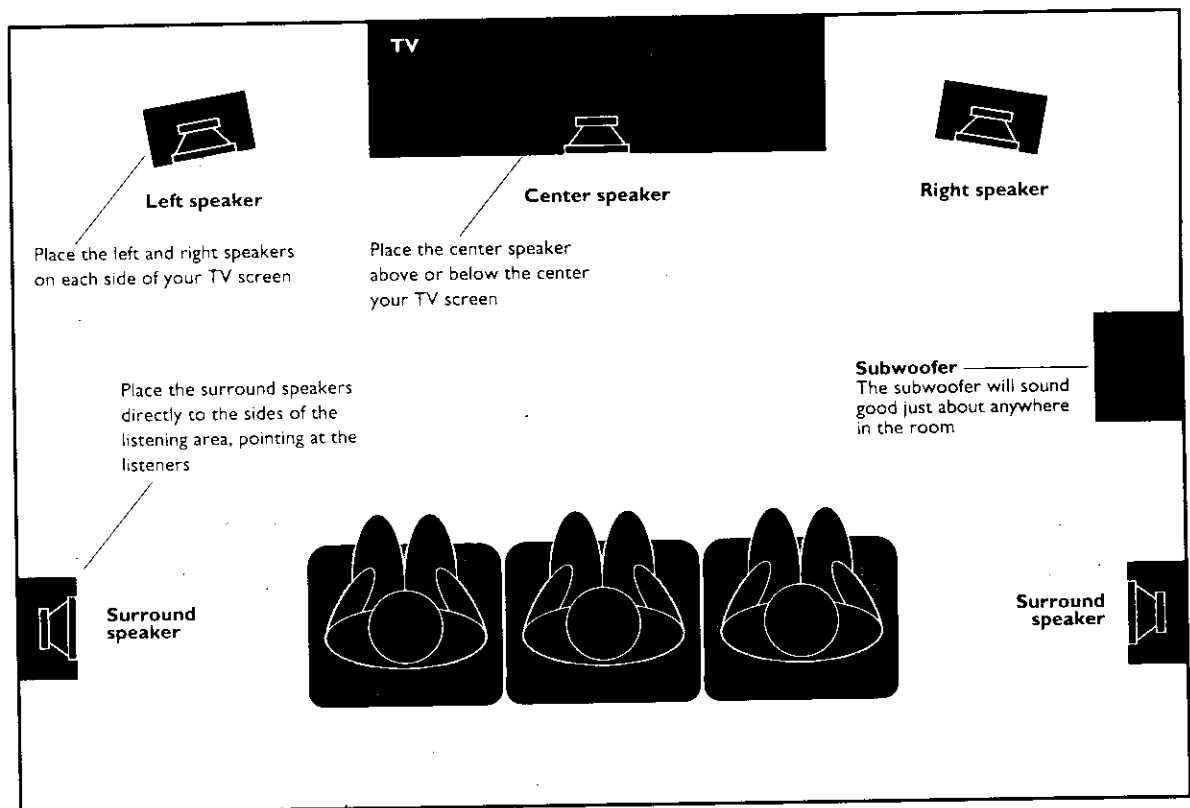

Connecting your components

Important:

Please wait until you've connected all of the cables before plugging any of the components into AC wall outlets and turning them on.

Connecting your speakers

Connect your speakers first. You'll have an easier time getting to the connections on the backs of the components before you connect all of the other cables.

- 1 Place the speakers in their approximate locations first, then leave a little extra speaker wire so you can fine-tune their locations.
- 2 Use the speaker wire supplied with the speakers. If you need longer wire, buy speaker wire that is 18-gauge or thicker. Remember, the smaller the number, the thicker the wire: 18-gauge wire is thicker than 20-gauge.

A few tips

- To save you time, we've removed the insulation from the ends of the speaker wire we supplied.
- When connecting speaker wires, be sure to connect positive connections to each other and negative connections to each other. Connecting positive to negative (+ to -) or negative to

positive (- to +) can cause poor sound quality.

- Never allow the positive and negative speaker wires to touch each other. Touching wires can cause a short circuit, which could damage your electronics.

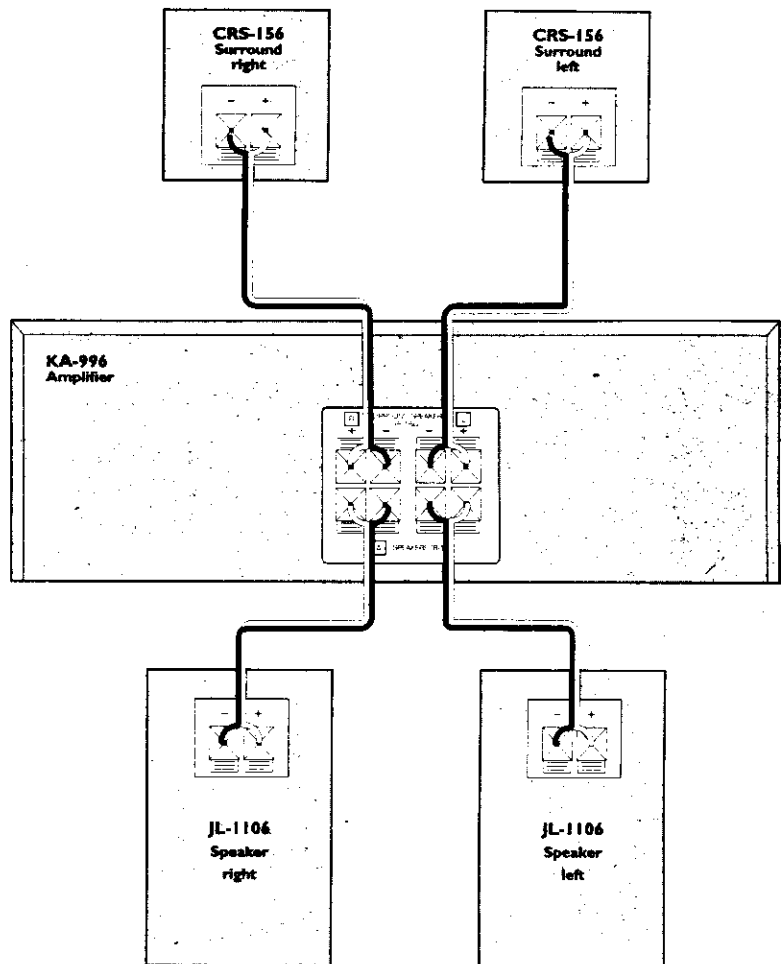

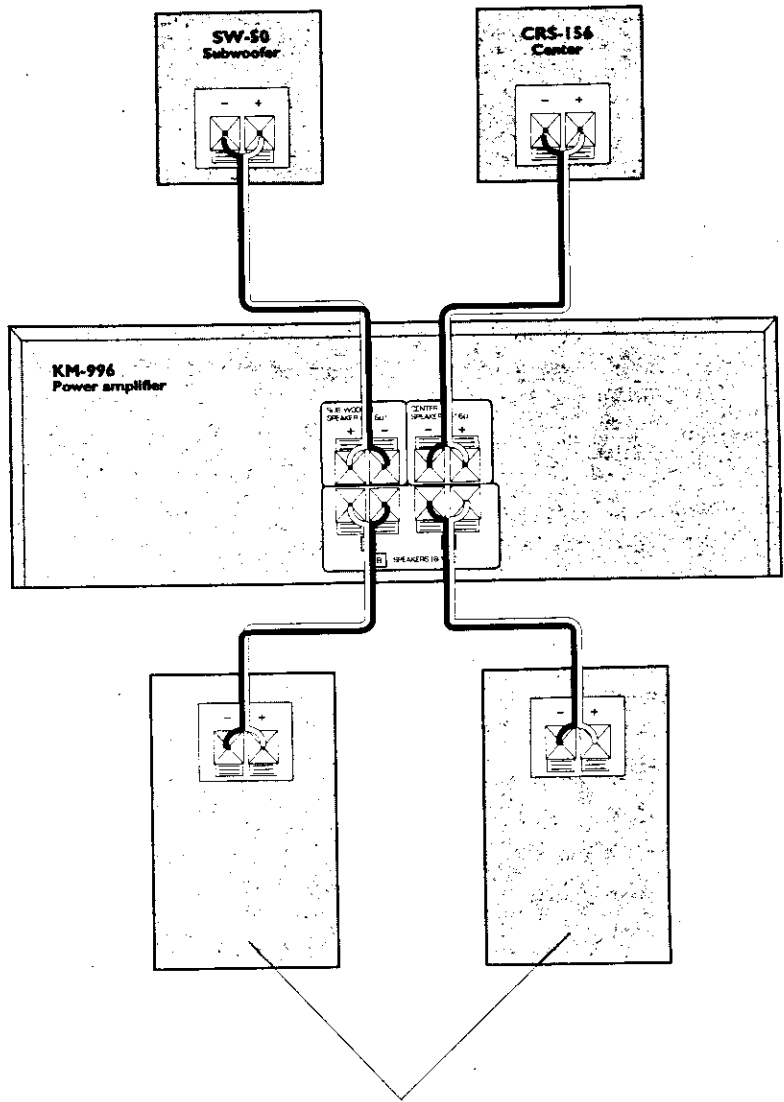

Optional second pair of speakers

To connect the wire:

- 1 Unlock the lever

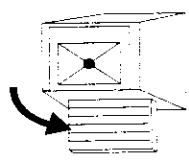

- 2 Insert the wire

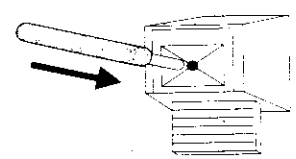

- 3 Lock the lever

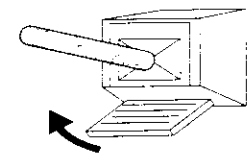

Connecting the power amplifier

Note:

Use this cable ONLY if you are using an optional second pair of speakers in your system.

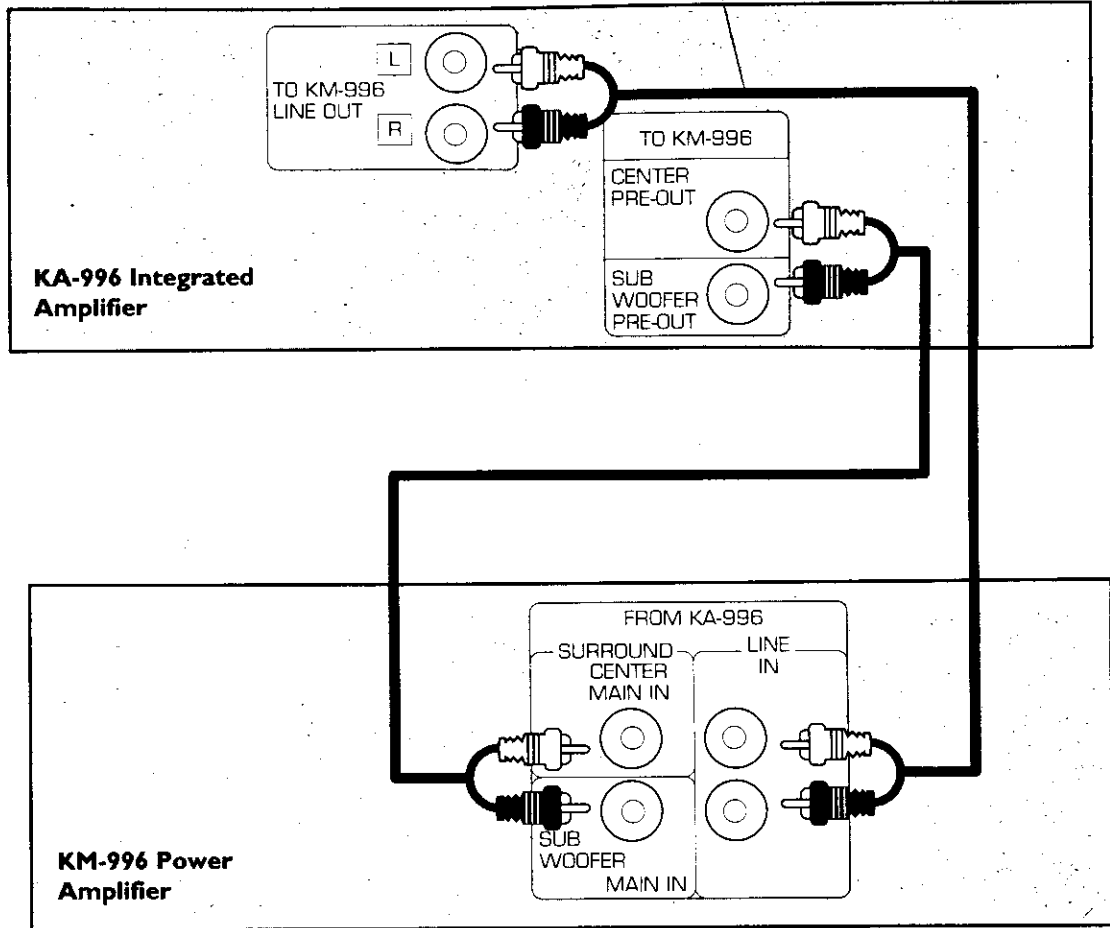

Connecting your tuner, CD player, cassette deck, and optional turntable

Use the cables that came with the audio and video components. You can connect any turntable that has a magnetic phono cartridge.

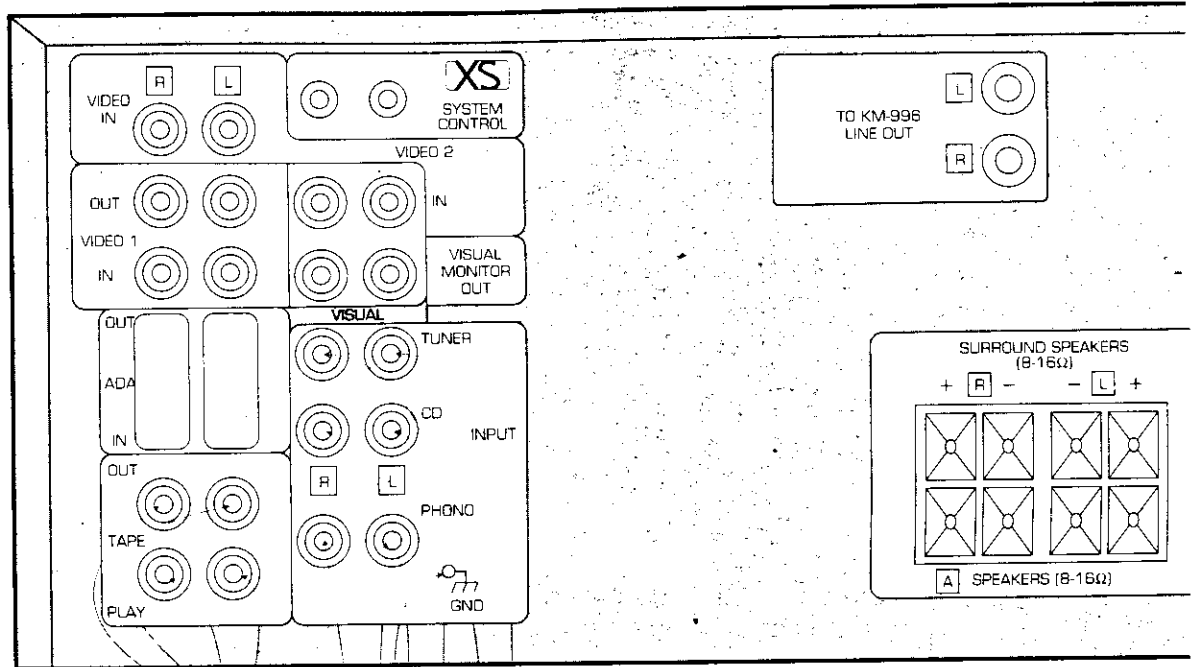

KA-996 Integrated Amplifier

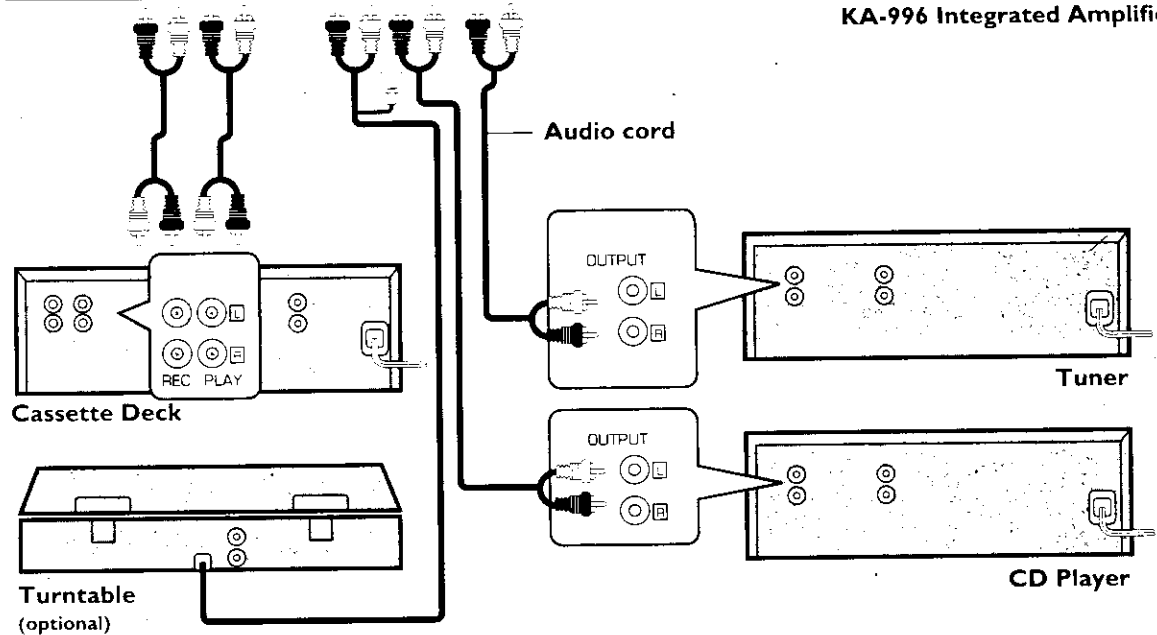

Connecting your antennas

The quality of your FM/AM reception depends on how well you place your antennas. So please follow the instructions carefully.

Connecting the antenna wires to the antenna jacks

- 1 Unlock lever



- 2 Insert wire



- 3 Lock lever



Using the AM indoor loop antenna (supplied)

Place the antenna as far away as possible from the main system, television, speaker wires, and power cords.

Rotate the antenna until you get the best reception.

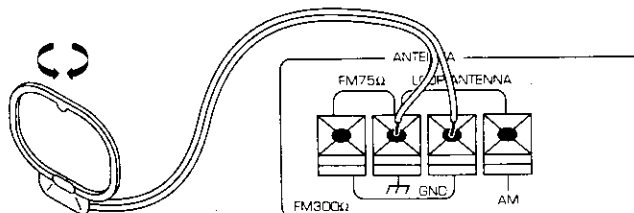

Using the FM indoor antenna (supplied)

Use this antenna until you can install an outdoor antenna. When you do, remove the indoor antenna.

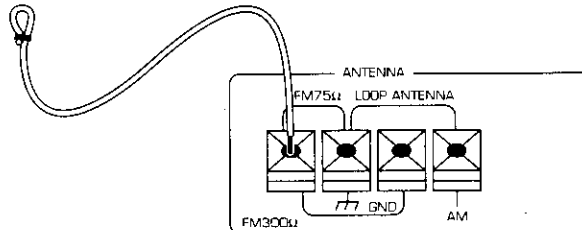

- 1 Remove the insulation from the wire tip, and twist the wire tightly to get rid of any loose strands.
- 2 Connect the end of the wire to the left-most antenna jack on the integrated amplifier.
- 3 Fully extend the antenna, and place it along a wall or bookshelf.
- 4 Adjust the antenna to find the position that provides the best reception.
- 5 Attach the looped end to the wall or bookshelf.

Using an AM outdoor antenna (optional)

If you're using the AM loop antenna, but reception is poor, run a vinyl-coated wire of more than 20 feet outdoors. Do not disconnect the loop antenna.

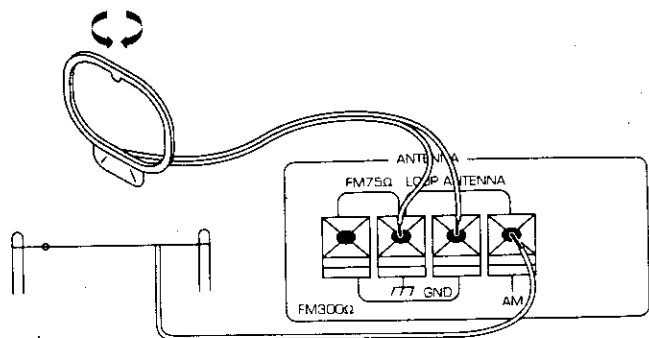

Using an FM outdoor antenna (optional)

For the best reception and sound quality, we recommend using an outdoor FM antenna. Since most outdoor antennas use either 75 ohm or 300 ohm connections, your system's integrated amplifier provides connections for both. Contact your local electronics dealer/installer for more information.

Connecting your video components

This diagram will help you connect your TV or VCR to your system. The cables shown in the diagram are not included with your system. If you need help, refer to the manual that came with each video component.

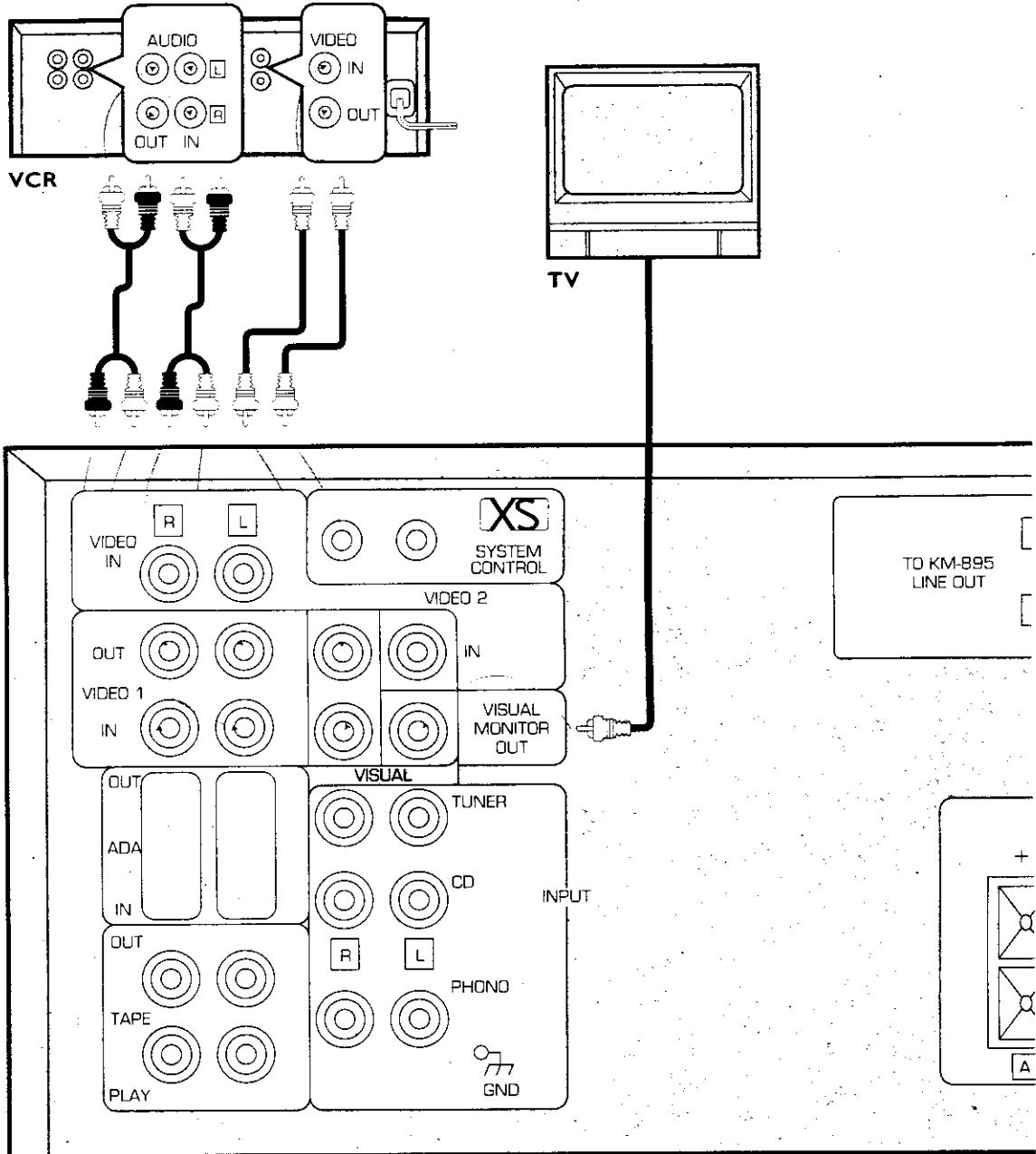

KA-996 Integrated Amplifier

Connecting the system control cables

Connect the system control cables as shown below. Be sure to push the plugs all the way in.

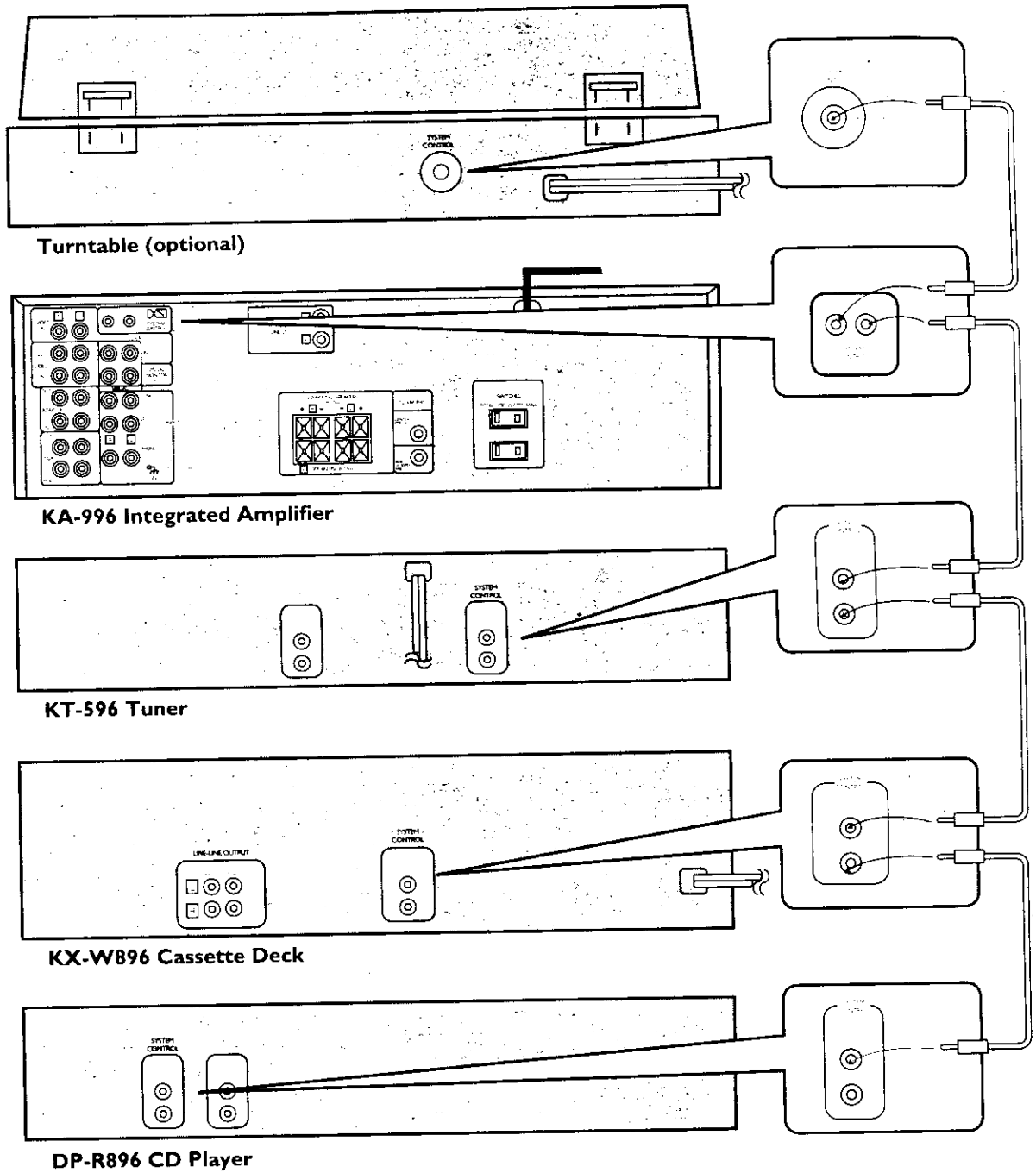

Connecting other audio components

You can connect a graphic equalizer or similar component to your system.

Remove the shorting plugs from the 'Adapter' jacks, and connect the component to those jacks.

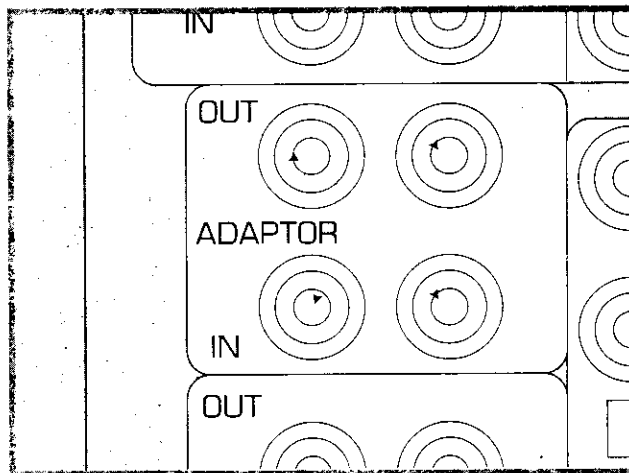
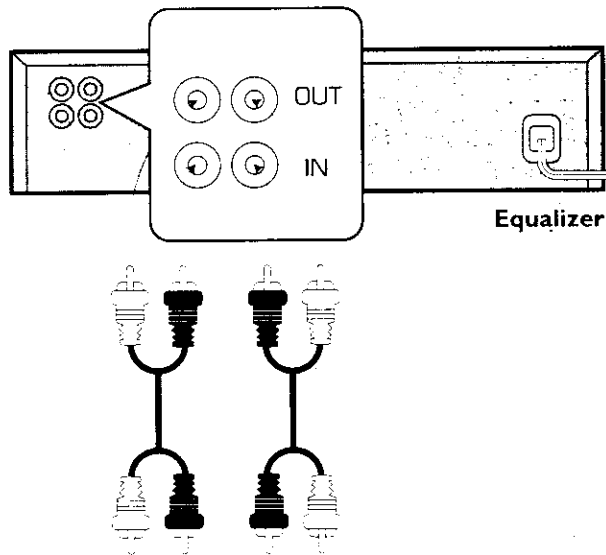

KA-996 Integrated Amplifier
(back detail)

A few tips:

- Read the manual that came with the other component.
- If you're using the 'Adapter' jacks, keep the shorting plugs for future use.
- If you're not connecting another component to the 'Adapter' jacks, be sure you insert the shorting plugs properly into the jacks. Otherwise, the sound will be cut off.
- Never plug a shorting plug into jacks other than the 'Adapter' jacks. You could damage the amplifier.

Turning ON the power

If you've connected all of the power and system control cables as we've shown, you can turn on the power to the entire system from the integrated amplifier.

- Press the power switch on the integrated amplifier (or the POWER button on the remote) to turn the entire system ON and OFF.

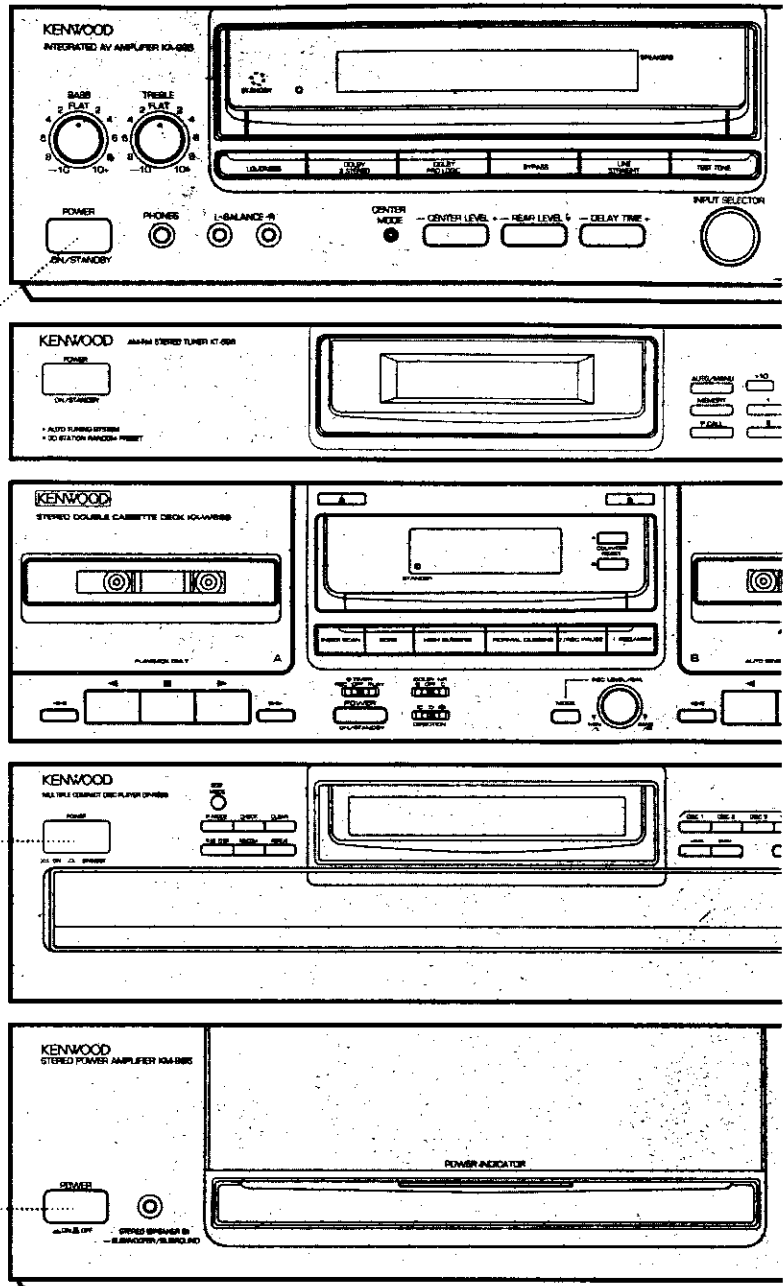

Important:

- Since the CD player and power amplifier have mechanical switches you must press their POWER switches when you turn the system ON for the very first time. After the first time, they will automatically turn ON and OFF with the rest of the system.

Tuning the speakers

Setting the center speaker mode

To get the best performance out of your system, you need to set the center speaker mode, even if you're not using a center speaker.

- 1 Turn the power to the system ON.
 - 2 Make sure that the integrated amplifier is in either the DOLBY PRO LOGIC or DOLBY 3 STEREO mode.
 - 3 Using a pen or other pointed object, press the CENTER MODE button on the integrated amplifier's front panel. Each time you press the button, your unit cycles through the mode settings and shows them on the integrated amplifier's display.
- If you're using the center speaker that came with your system, or another small or medium-size center speaker, select 'Normal'.
 - If you're using a large center speaker, select 'Wideband'.
 - If you're not using a center speaker, select 'Phantom' (the center channel signal is sent to the left and right speakers).

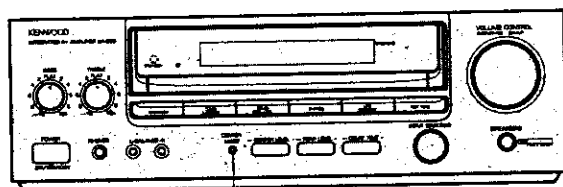

CENTER MODE
button

Calibrating the speaker levels

Calibrating is an important step in making sure your system sounds as good as possible. During calibration, you're balancing the sound coming from each speaker to create the right surround-sound environment.

Loading batteries into your remote

You'll use the remote to calibrate the system, so you'll need to load the batteries. You'll find the instructions for the remote in your 'Using Your Kenwood Audio/Video System' manual.

Doing the calibrating

- 1 Eliminate as many external noise sources as possible.
- 2 Turn the system's power ON.
- 3 Select DOLBY PRO LOGIC mode.
- 4 Press the AUDIO button on the remote until AUDIO appears in the remote's display.
- 5 Set the volume to -20 dB. If this level is uncomfortably loud, lower the volume to -25 dB.
- 6 Press the FUNCTION button on the remote.

You'll hear test noise cycle between the channels in the following order:

LEFT>CENTER>RIGHT>SURROUND. (If the center channel is in the PHANTOM mode, it cannot be adjusted.)

- 7 Sit in the place where you and your guests are most likely to sit while watching movies or listening to music. Listen to the test noise level of each channel carefully.
- 8 If the left and right channels are not both the same volume, use the BALANCE control on the integrated amplifier's front panel to adjust them so they both play the test noise at the same volume.

- 9** If the center channel is not the same volume as the left and right speakers, use the ► and ◀ buttons to adjust it so it plays the test noise at the same volume.

The test noise stops cycling and remains in the center channel while it's being adjusted.

The integrated amplifier displays the level of the center channel while it's being adjusted.

- 10** If the surround channel is not the same volume as the other speakers, use the ► and ◀ buttons to adjust it so it plays the test noise at the same volume.

The test noise stops cycling and remains in the surround channel while it's being adjusted.

The integrated amplifier displays the level of the surround channel while it's being adjusted.

- 11** When all of the channels sound like they're the same volume, you've balanced your system.

- 12** Press the FUNCTION button on the remote to turn off the test noise.

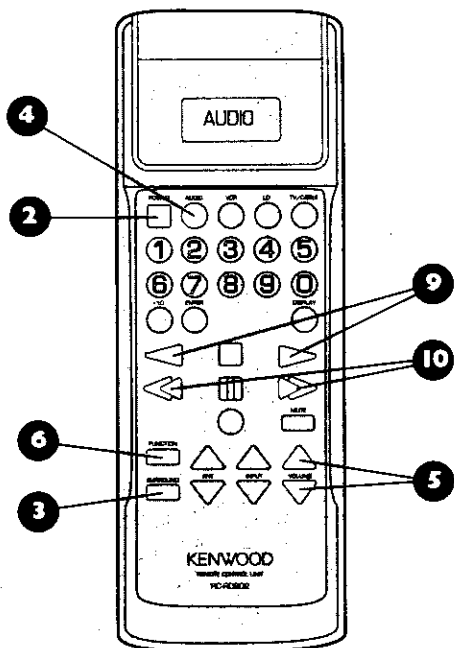

You can also make the adjustments by using the CENTER LEVEL and REAR LEVEL buttons on the integrated amplifier's front panel (but it's easier with the remote because you can sit in the listening area).

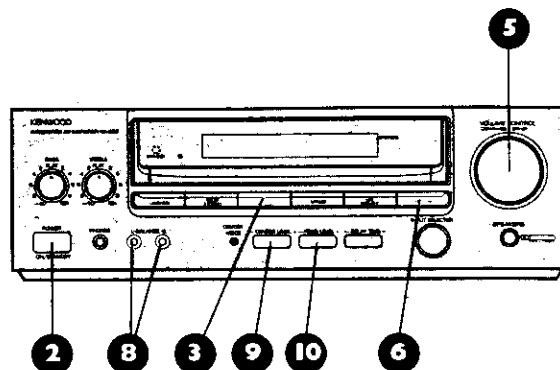

Setting the subwoofer level

The level control for the subwoofer is located on the rear panel of the power amplifier.

- 1 Select DOLBY PRO LOGIC mode.
- 2 Play video material with strong bass content that you're familiar with.
- 3 Adjust the subwoofer level so that it blends well with the other speakers.
- 4 Confirm the level by playing music with strong bass content in the BYPASS mode.

If you're using your system only for music, adjust the subwoofer in the BYPASS mode, using music.

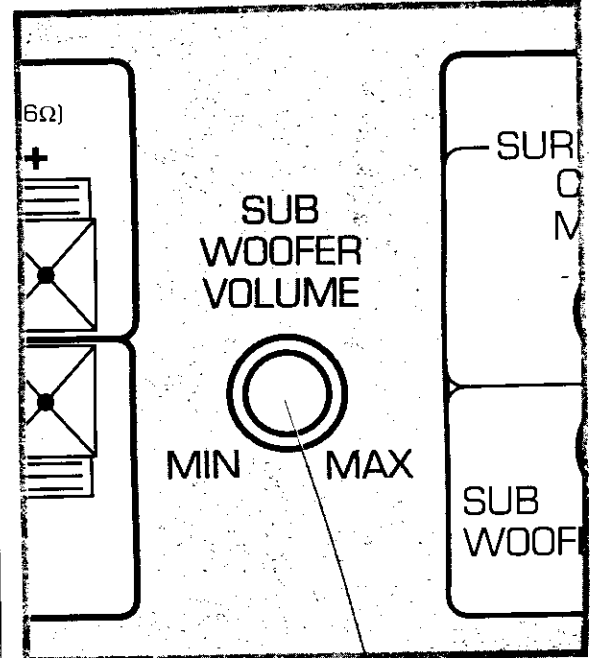

KM-996 Power Amplifier
(back detail)

Subwoofer volume
control knob

Adjusting the delay time

Setting the delay time compensates for the way our ears receive sound from different directions. When you're watching a movie, the surround speakers are typically closer to you than the front speakers. Without using delay, sound from the surround speakers would reach your ears at the wrong time compared to the front speakers—which would ruin the surround effect. Adjusting for the delay time blends the sound of the front and surround speakers. Unless you rearrange your room, you should only need to make this adjustment once.

Before you start

- 1 Measure the distance from the main seating area to the front speakers and the distance from the main seating area to the surround speakers.
- 2 Look at the point on the graph below that represents where these distances meet, and note the delay time.

Delay times (ms)

Distance to surround speakers	35 ft					15	
	30 ft					15	15
	25 ft			15	15	20	
	20 ft			15	15	20	25
	15 ft		15	15	20	25	30
	10 ft	15	15	20	25	30	30
	5 ft	15	20	25	30	30	30
	5 ft	10 ft	15 ft	20 ft	25 ft	30 ft	
	Distance to front speakers						

Doing the adjusting

You can adjust the delay time from 15 to 30 milliseconds (ms). In the average living room, 20 ms sounds good, but you can fine-tune the delay time until the sound from the front and surround speakers blends.

- 1 Select DOLBY PRO LOGIC mode.
- 2 Press the AUDIO button on the remote until AUDIO appears in the remote's display.

- 3 Use the ANY buttons on the remote to increase or decrease the desired delay time shows on the amplifier's display. Each time you press the ANY buttons (up or down) you adjust the delay time 5 ms.

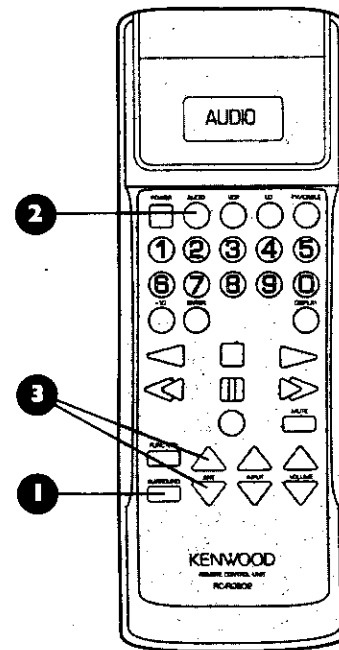

You can also make the adjustments by using the DELAY TIME buttons on the integrated amplifier's front panel.

